

EDITION	DESCRIPTION	DRAWN	DATE

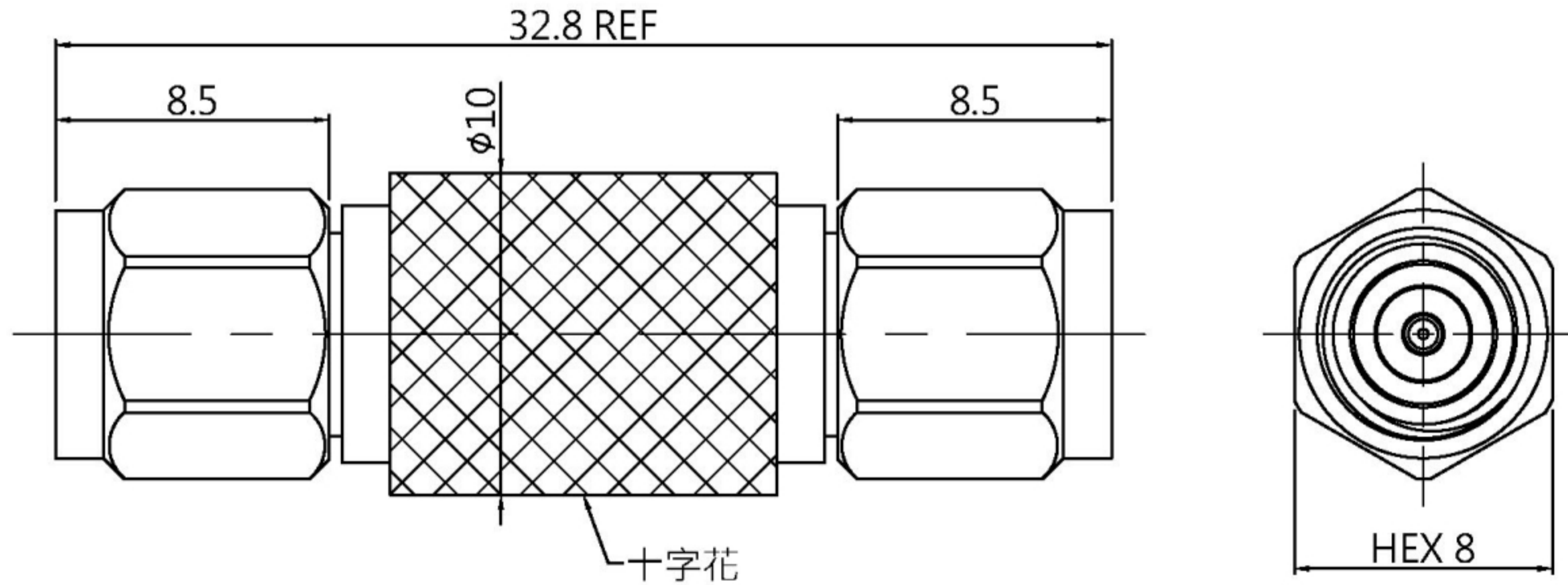

ChoiceRight Electronic Inc

TITLE
ADAPTOR, 2.92mm(m)-(m)

CHECKED
J. Lin

Edit Code.
292MS292MADP015000-1

DRAWER
Eddie

FILE NO. E:

EDITION: A

DATE 11/15/16

SCALE

1/1

UNIT

MM

TOLERANCES

DIMENSIONS ARE IN MILLIMETER

UNLESS OTHERWISE SPECIFIED

0-6 = ±0.08

6-30 = ±0.1

30-120 = ±0.2

120-300 = ±0.3

300-600 = ±0.4

600-1200 = ±0.5

6	C RING	2	STAINLESS STEEL	--
5	SHELL	2	STAINLESS STEEL	PASSIVATED
4	INSULATOR	1	PEI	NATURAL
3	PIN	1	BRASS	GOLD
2	BODY	1	STAINLESS STEEL	PASSIVATED
1	BODY	2	BRASS	GOLD
NO	DESCRIPTION	Q'TY	MATERIAL	FINISH