

EDITION	DESCRIPTION	DRAWN	DATE
	UPDATE DRAWING FORMAT		01/10/04

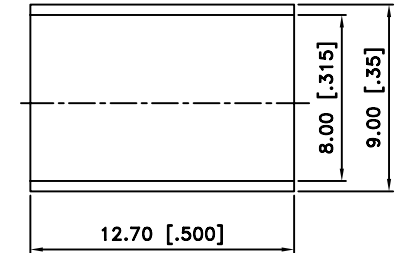
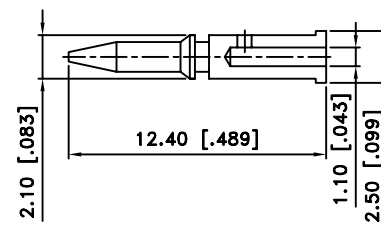
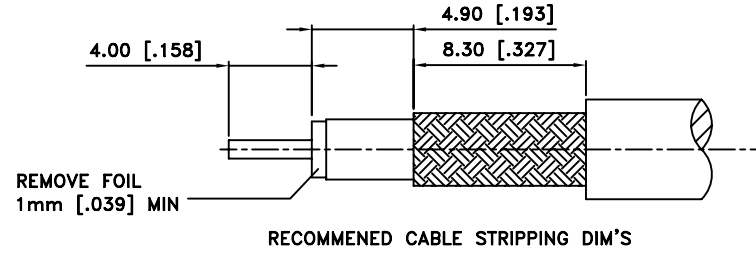
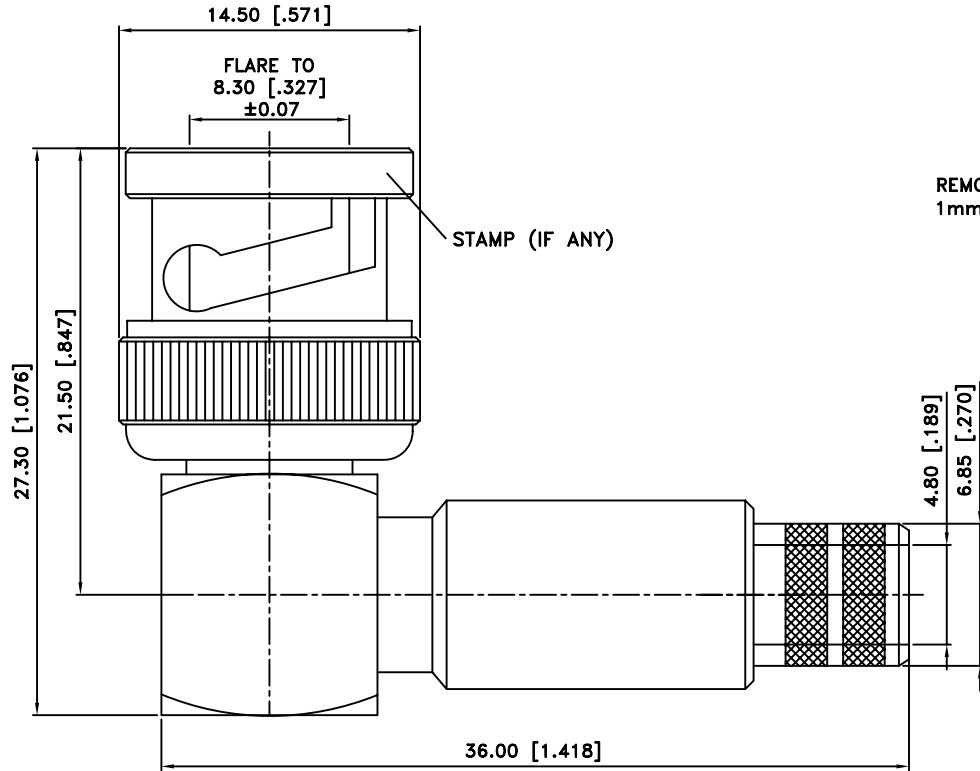

NOTE:  
 1. CRIMPED FERRULE  
 HEX CRIMP SIZE .319"  
 2. CRIMPED CONTACT PIN  
 HEX CRIMP SIZE .068"

NO	Description	Q'ty	Material	Finish
5	FERRULE	1	COPPER	NICKEL
4	CONTACT PIN	1	PHOS.BRONZE	GOLD
3	CONTACT PIN	1	BRASS	GOLD
2	INSULATOR	1	TEFLON	NATURAL
1	BODY	1	BRASS	NICKEL

 ChoiceRight Electronic Inc

TOLERANCES			
DIMENSIONS ARE IN MILLIMETER			
UNLESS OTHERWISE SPECIFIED ARE IN MILLIMETERS			
DIMENSIONS IN [ ] ARE IN INCH AND FOR CUSTOMER REFERENCE ONLY.			
UNLESS OTHERWISE SPECIFIED TOLERANCES FOR MILLIMETER ARE:			
0.5	– 8mm	± 0.20mm	
0.5	– 30mm	± 0.40mm	
0.5	– 150mm	± 0.50mm	
UNLESS OTHERWISE SPECIFIED TOLERANCES FOR INCH ARE:			
.050	– .318	± 0.0075"	
.318	– 1.180	± 0.0150"	
1.180	– 4.724	± 0.0300"	
SCALE	NA	UNIT	MM

TITLE	BNC R/A CRIMP PLUG (FOR RG-6/U CABLE)	CHECKED	J. Lin
Edt Code	BNCMR00105A7500-1	DRAWER	Eddie
FILE NO. D:\		EDITION: B	DATE 01/10/04