

REV.	DATE	ECR NO.	DESCRIPTION
NC	10/08/06	XXXXXX	INITAL RELEASE

5/8-24UNEF-2A STAMP (IF ANY)

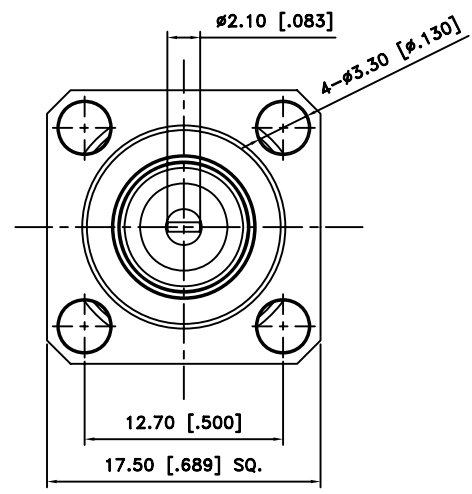
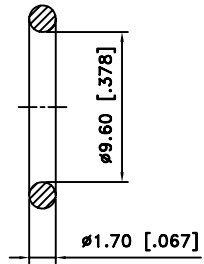
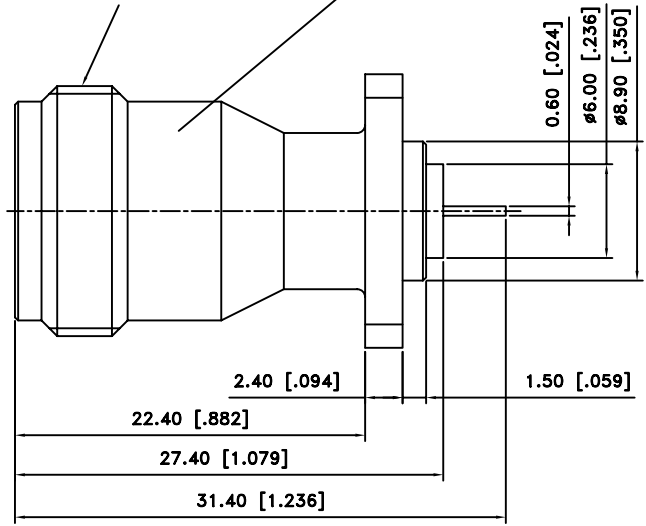

ChoiceRight Electronic Inc

UNLESS OTHERWISE SPECIFIED DIMENSIONS ARE IN MILLIMETERS. DIMENSIONS IN [] ARE IN INCHES AND FOR CUSTOMER REFERENCE ONLY.

UNLESS OTHERWISE SPECIFIED TOLERANCES FOR MILLIMETERS ARE:
 0.5 - 8mm ± 0.20mm
 8 - 30mm ± 0.40mm
 30 - 120mm ± 0.50mm

UNLESS OTHERWISE SPECIFIED TOLERANCES FOR MILLIMETERS ARE:
 .020 - .315 = ± 0.007"
 .315 - 1.180 = ± 0.015"
 1.180 - 4.724 = ± 0.020"

TITLE	N PANEL RECEPT. JACK	CHECKED	J. Lin
Edt Code.	NFS009015000-1	DRAWER	Eddie
FILE NO. C:	EDITION: A	DATE 10/08/06	

SCALE	NA	UNIT	MM
-------	----	------	----

7				
6				
5				
4	GASKET	SILICONE	RED	1
3	CONTACT PIN	PHOSPHOR BRONZE	GOLD	1
2	INSULATOR	PTFE	NATURAL	1
1	BODY	BRASS	NEXCOTE	1
NO	DESCRIPTION	MATERIAL	FINISH	QTY