

EDITION	DESCRIPTION	DRAWN	DATE
	UPDATE DRAWING FORMAT		01/23/04

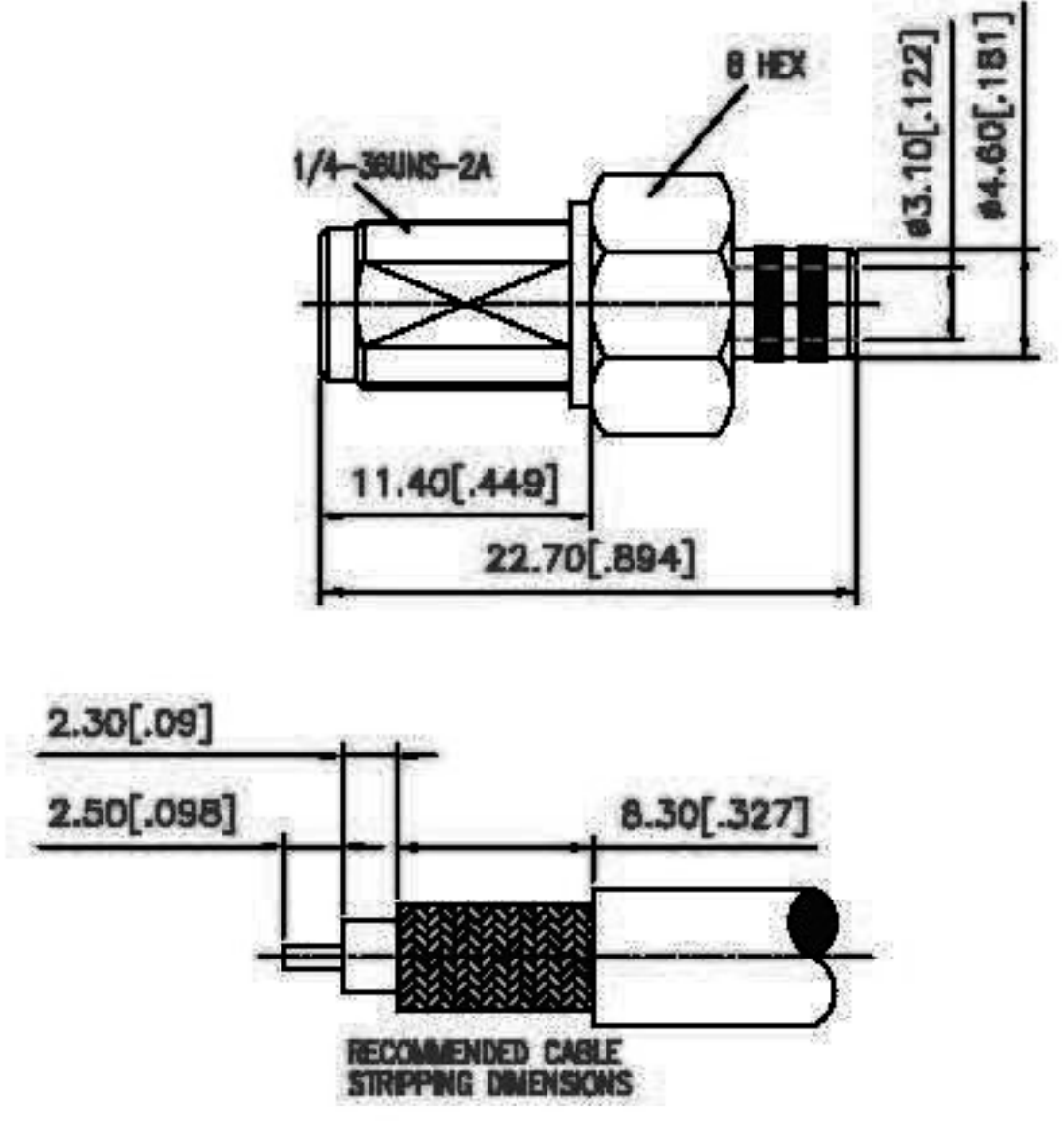

NOTE:
 1. CONTACT PIN TO SOLDER
 2. MAX. PANEL THICKNESS=2.4mm

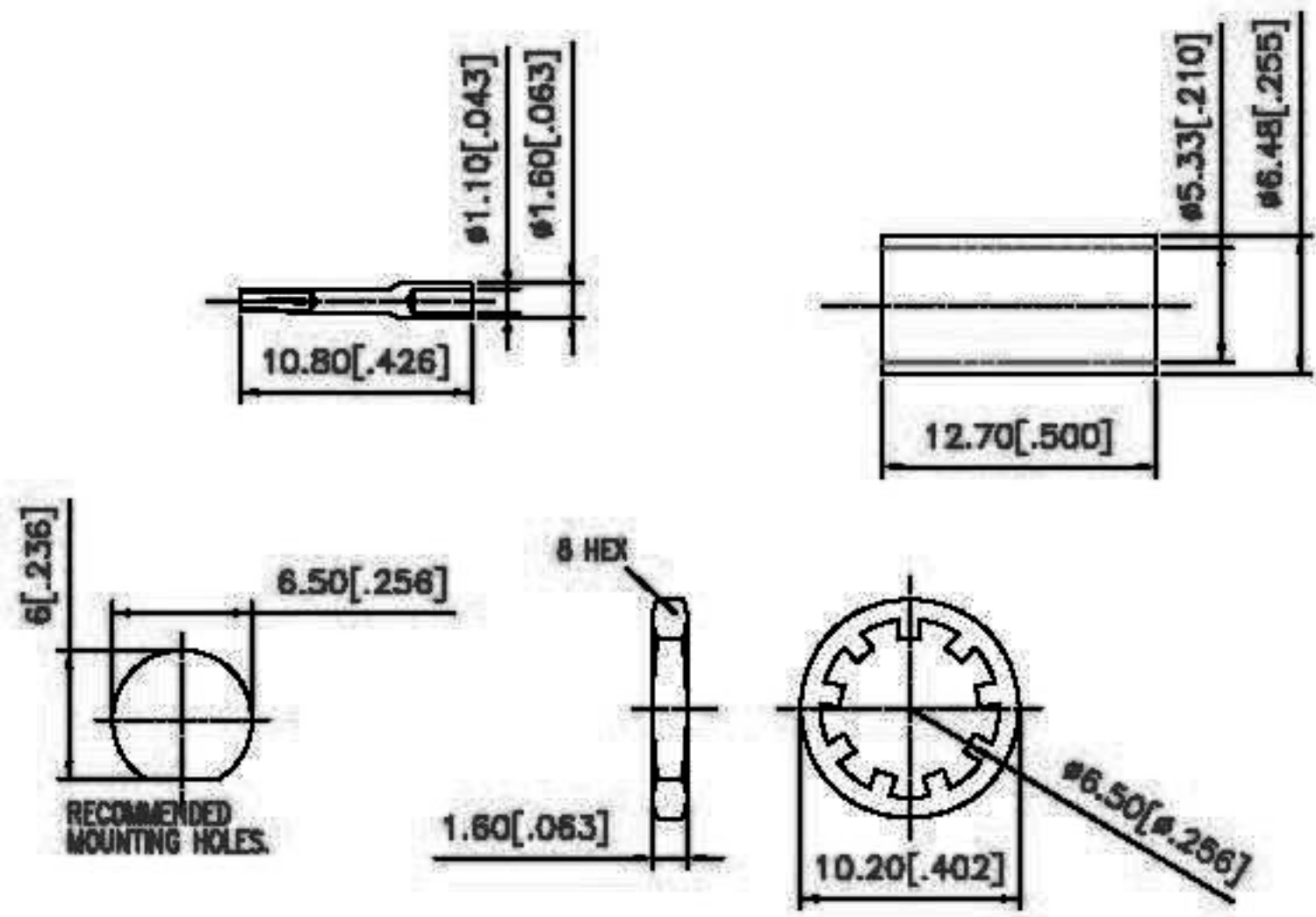

TITLE BNC BULKHEAD CRIMP JACK
 (FOR RG-58C/U, 58/U CABLE)
 Edit Code: SMAFBS00104F5000-1
 FILE NO. C:

CHECKED J. Lin
 DRAWER Eddie
 EDITION: A DATE 01/23/04

TOLERANCES					
DIMENSIONS ARE IN MILLIMETER					
UNLESS OTHERWISE SPECIFIED TOLERANCES FOR INCHES ARE					
0.5-8mm±0.2mm					
8-30mm±0.1mm					
30-120mm±0.05mm					
UNLESS OTHERWISE SPECIFIED TOLERANCES FOR INCHES ARE					
.020-.315=±0.007"					
.315-1.180=±0.015"					
1.180-4.724=±0.020"					
SCALE	NA	UNIT	MM		

6	FERRULE	1	COPPER	GOLD
5	LOCK WASHER	1	BRASS	GOLD
4	HEX NUT	1	BRASS	GOLD
3	CONTACT PIN	1	BER COPPER	GOLD
2	INSULATOR	1	TEFLON	NATURAL
1	Body	1	BRASS	GOLD
NO	Description	Q'ty	Material	Finish