

EDITION	DESCRIPTION	DRAWN	DATE
	INITIAL RELEASE		05/01/04

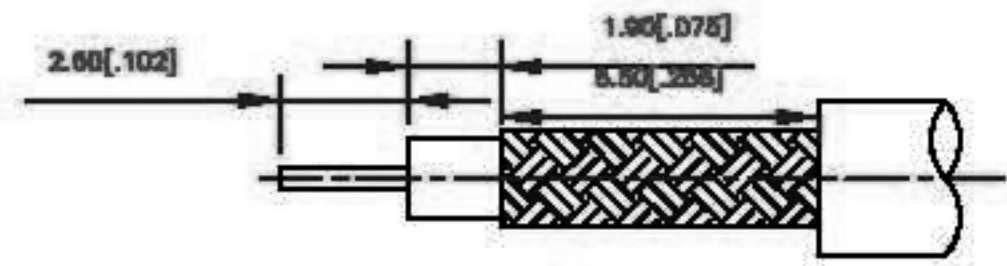

RECOMMENDED CABLE STRIPPING

NOTE:
 1. CRIMPED FERRULE
 HEX CRIMP SIZE .128"
 2. CONTACT PIN TO SOLDER

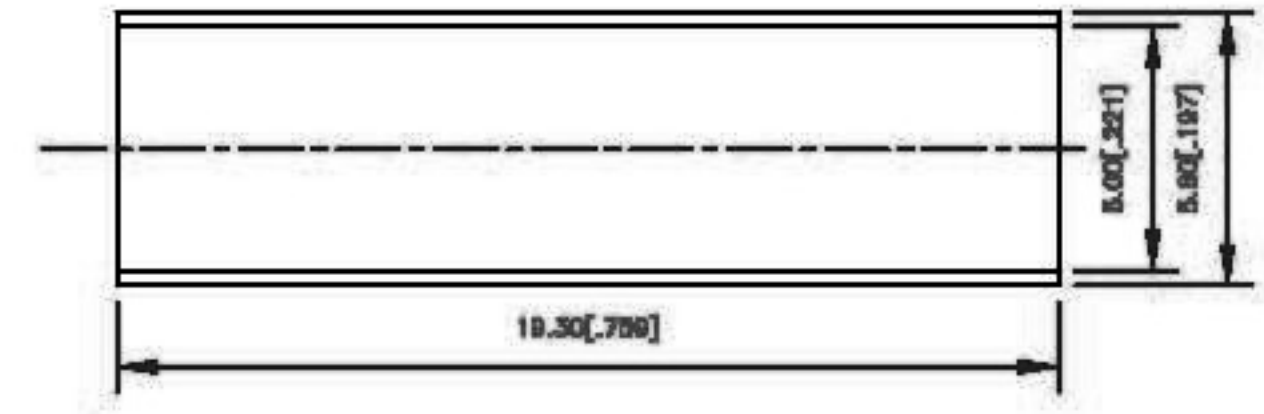
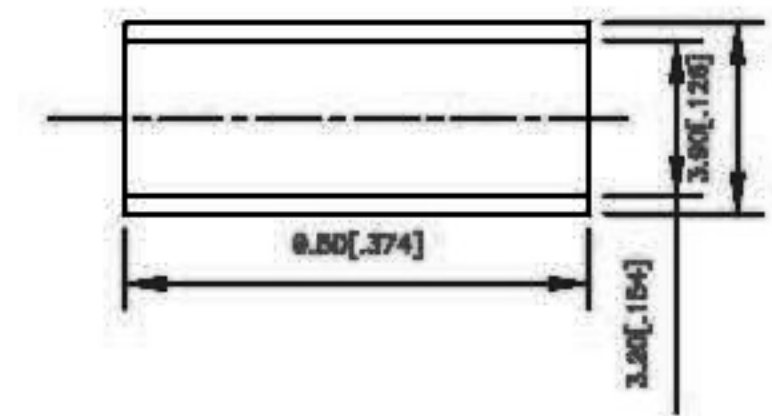
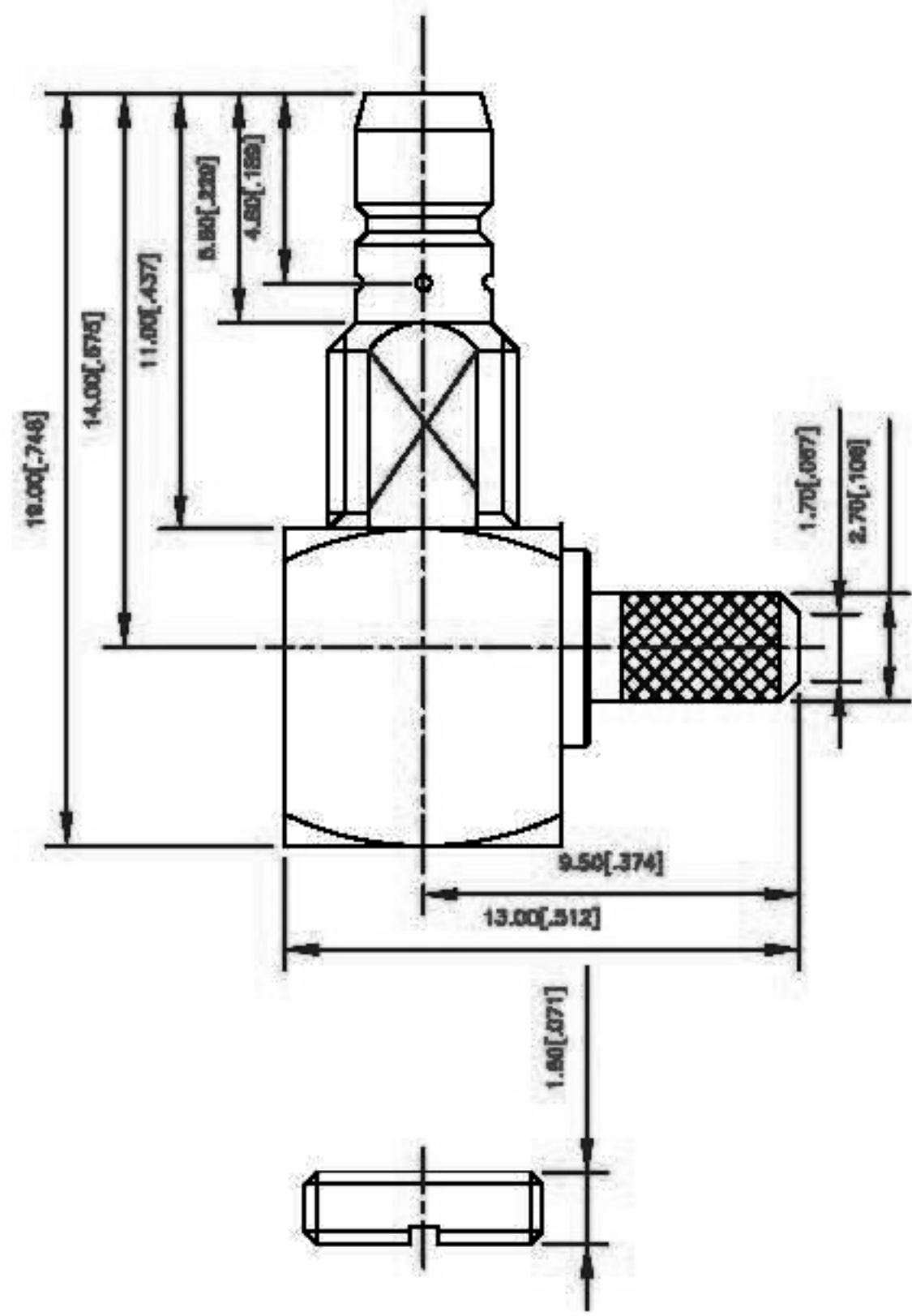
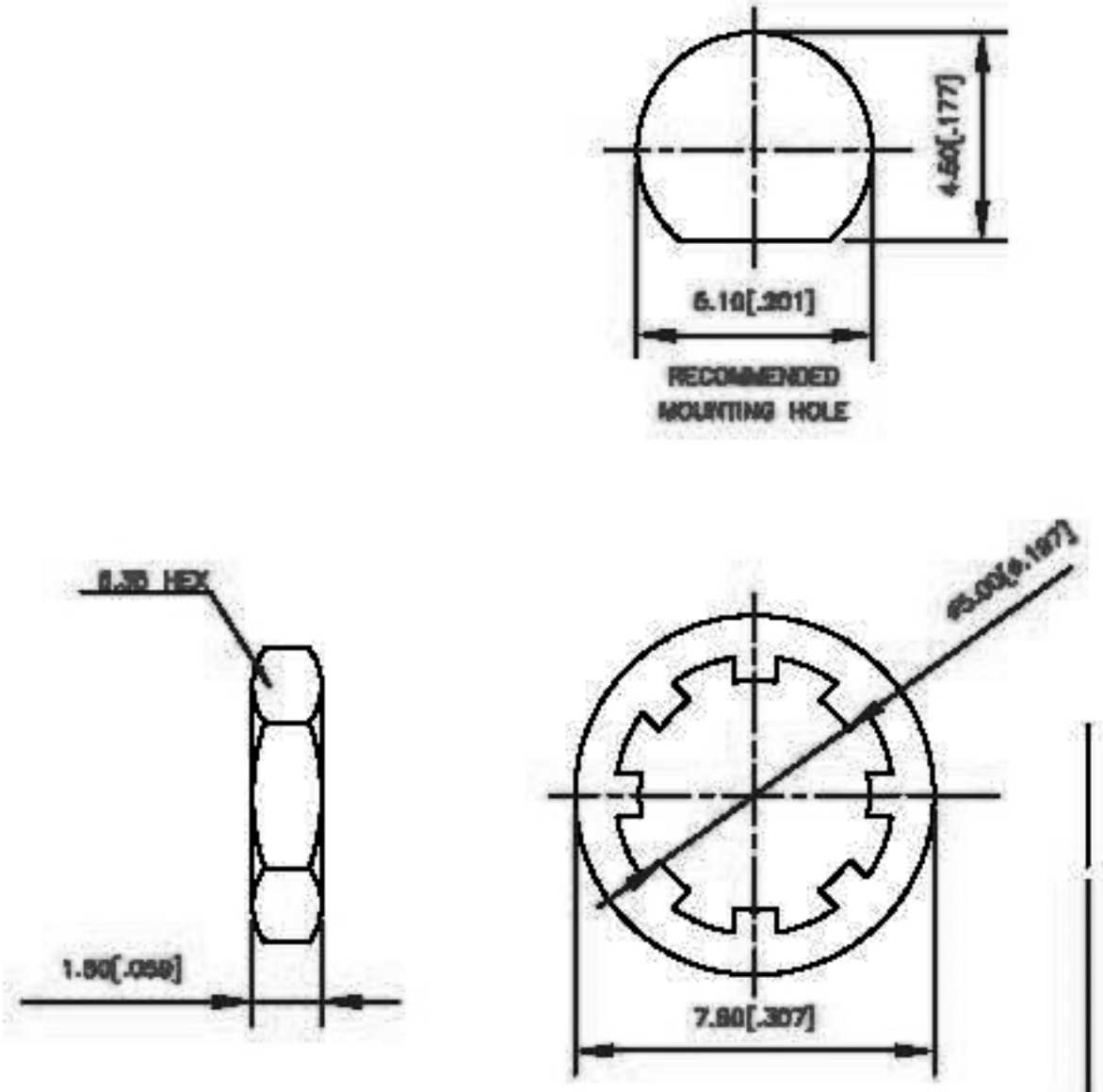

TITLE SMB R/A Bulkhead Crimp Jack
 (FOR RG174/U, 188A/U, 316/U)
 Edit Code: SMBFBR00109L5000-1
 FILE NO. C:

CHECKED J. Lin
 DRAWER Eddie
 EDITION: A DATE 05/08/07

TOLERANCES	
DIMENSIONS ARE IN MILLIMETER	
UNLESS OTHERWISE SPECIFIED TOLERANCES FOR INCHES ARE 0.5-8mm ±0.2mm 8-30mm ±0.1mm 30-120mm ±0.05mm UNLESS OTHERWISE SPECIFIED TOLERANCES FOR INCHES ARE .020-.315 = ±0.007" .315-1.180 = ±0.015" 1.180-4.724 = 0.020"	
SCALE	1:1
UNIT	MM

7	COVER	1	BRASS	GOLD
6	FERRULE	1	COPPER	GOLD
5	HEX NUT	1	BRASS	GOLD
4	LOCK WASHER	1	BRASS	GOLD
3	CONTACT PIN	1	BRASS	GOLD
2	INSULATOR	1	TEFLON	NATURAL
1	BODY	1	BRASS	GOLD
NO	Description	Qty	Material	Finish