

EDITION	DESCRIPTION	DRAWN	DATE
	DESCRIPTION\APPROVED\DATE		ZONE

NOTE:FINSH (PLATING) THCKNESS IN MICRO-INCHES

- 1.BRASS PER QQ-B-626
- 2.GOLD PL.3 MIN THICK OVER NICKEL PL. 100 MIN. THICK OVER COPPER STRIKE
- 3.GOLD PL 30 MIN. THICK OVER NICKEL P,100 MIN. THICK OVER COPPER STRIKE
- 4.TEFLON MIL-P-19488

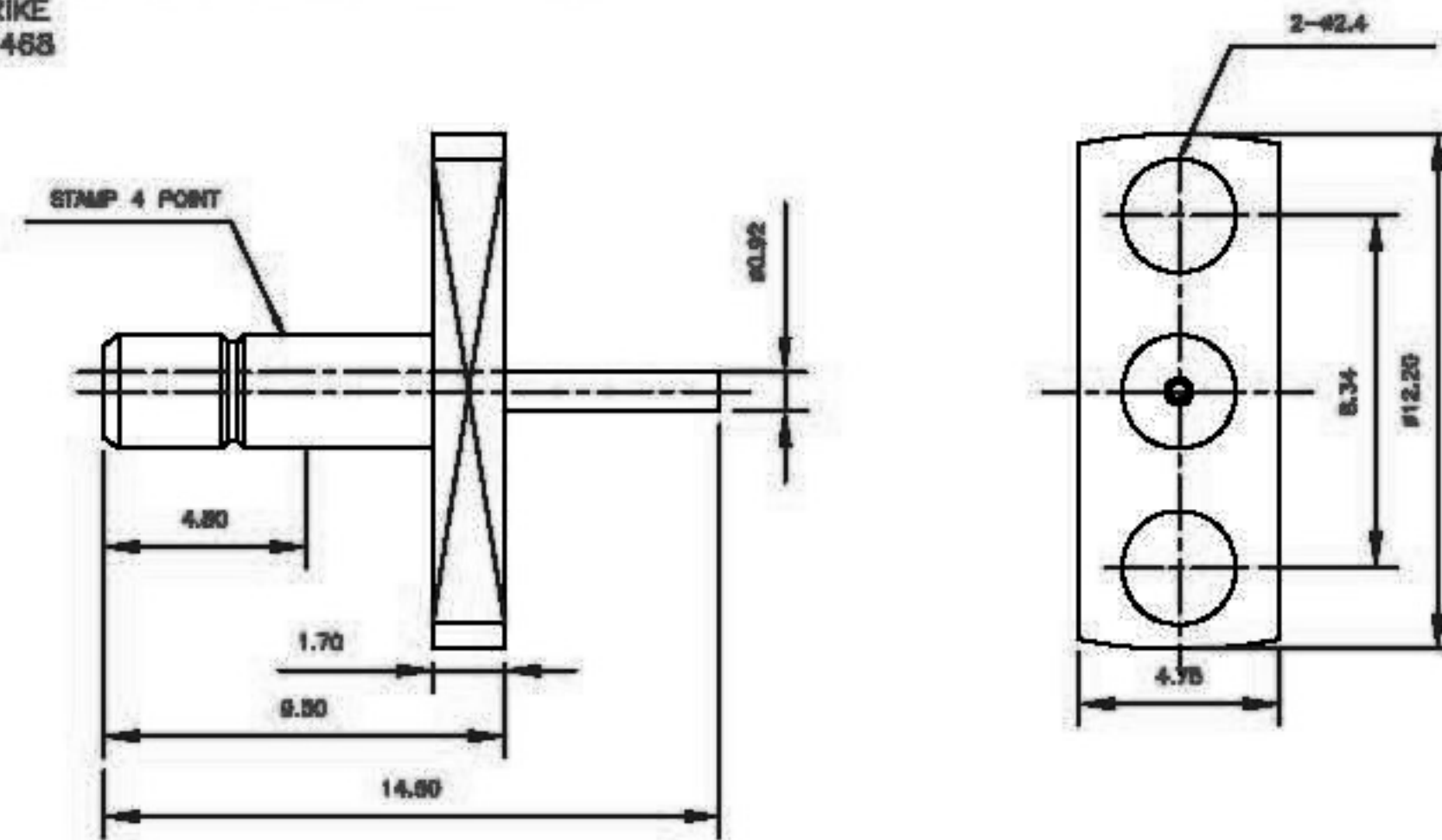

ChoiceRight Electronic Inc

TOLERANCES	
DIMENSIONS ARE IN MILLIMETER	
UNLESS OTHERWISE SPECIFIED TOLERANCES	
0.5-8mm±0.2mm	
8-30mm±0.4mm	
30-120mm±0.6mm	
120-.315±1°	
.315-1000±16°	
1000-0.020±2.4°	

TITLE
SMB PANEL MOUNT RECEPTACLE JACK

Edt Code.
SMBFS009015000-1

CHECKED
J. Lin

DRAWER
Eddie

FILE NO. C: EDITION: A DATE 08/04/08

SCALE 1:1 UNIT MM

3	CONTACT PIN	1	NOTE 3	NOTE 3
2	INSULATOR	1	NOTE 4	NATURAL
1	BODY	1	NOTE 2	NOTE 2
NO	Description	Qty	Material	Finish