

REV.	DATE	DESCRIPTION
NA	05/27/97	INITAL RELEASE
A	05/01/04	UPDATE DRAWING FORMAT

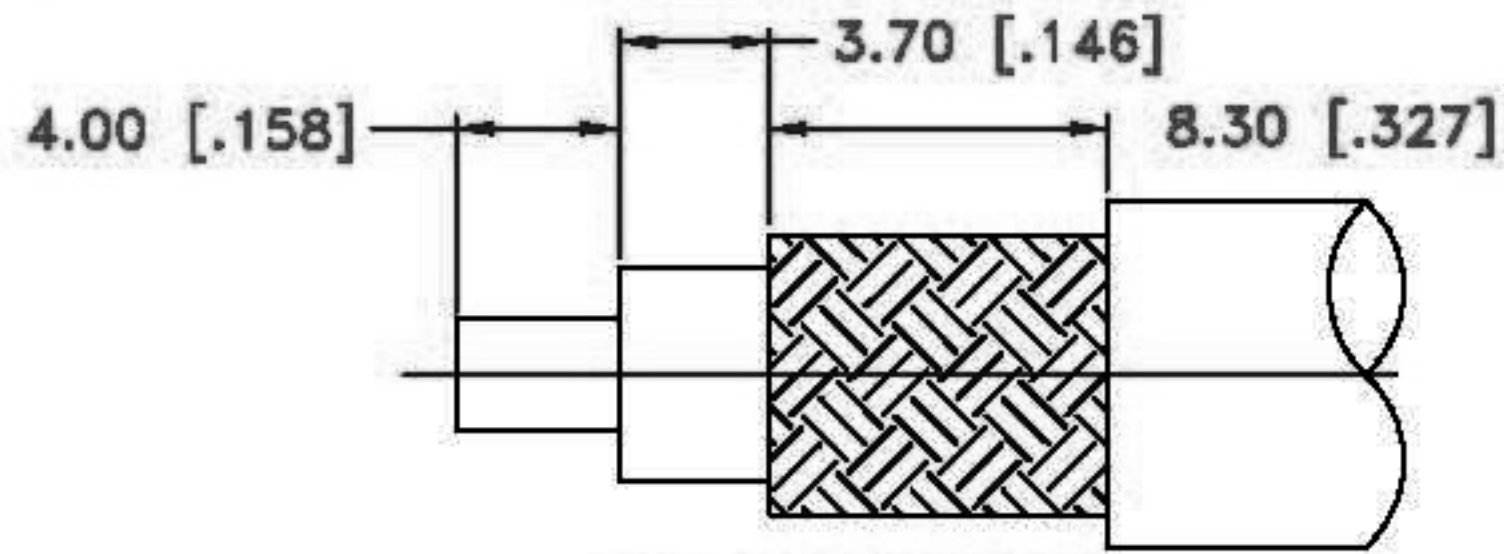

RECOMMENDED
STAMP (IF ANY) CABLE STRIPPING DIM'S

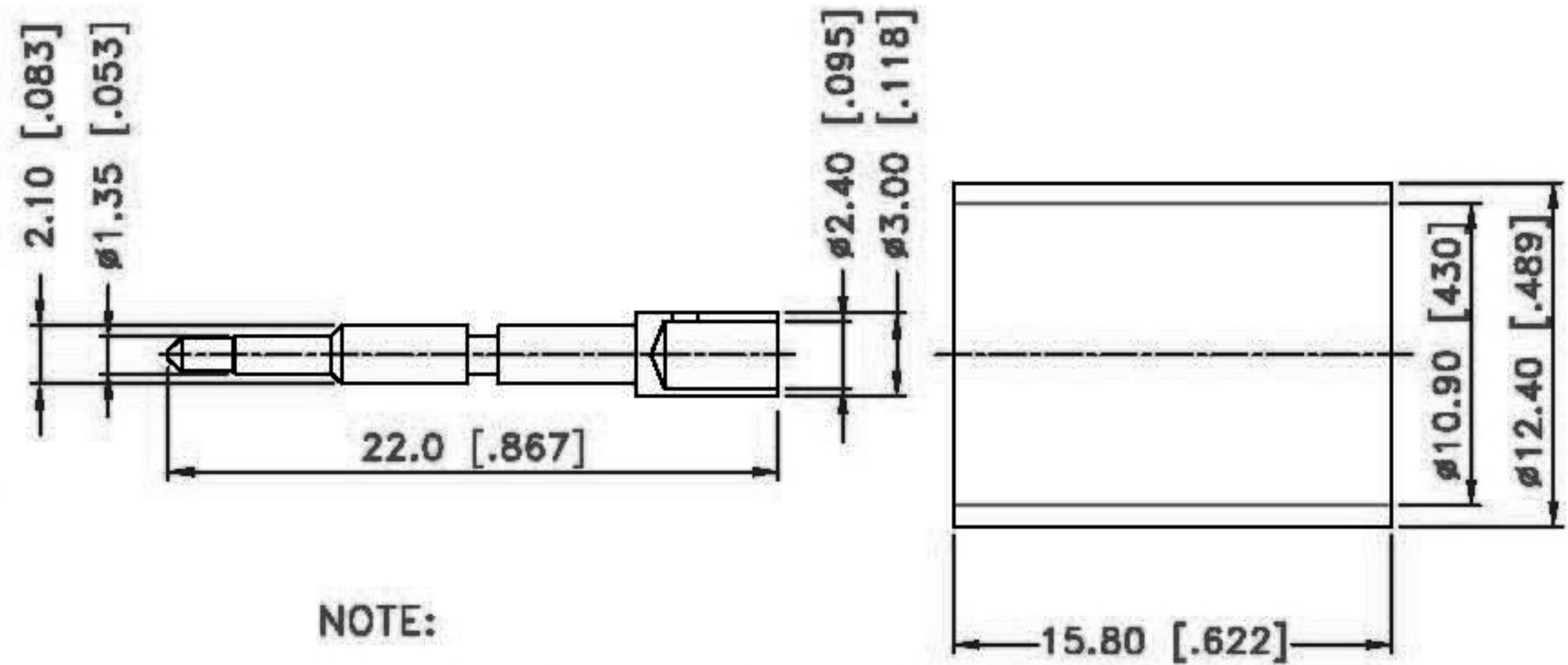
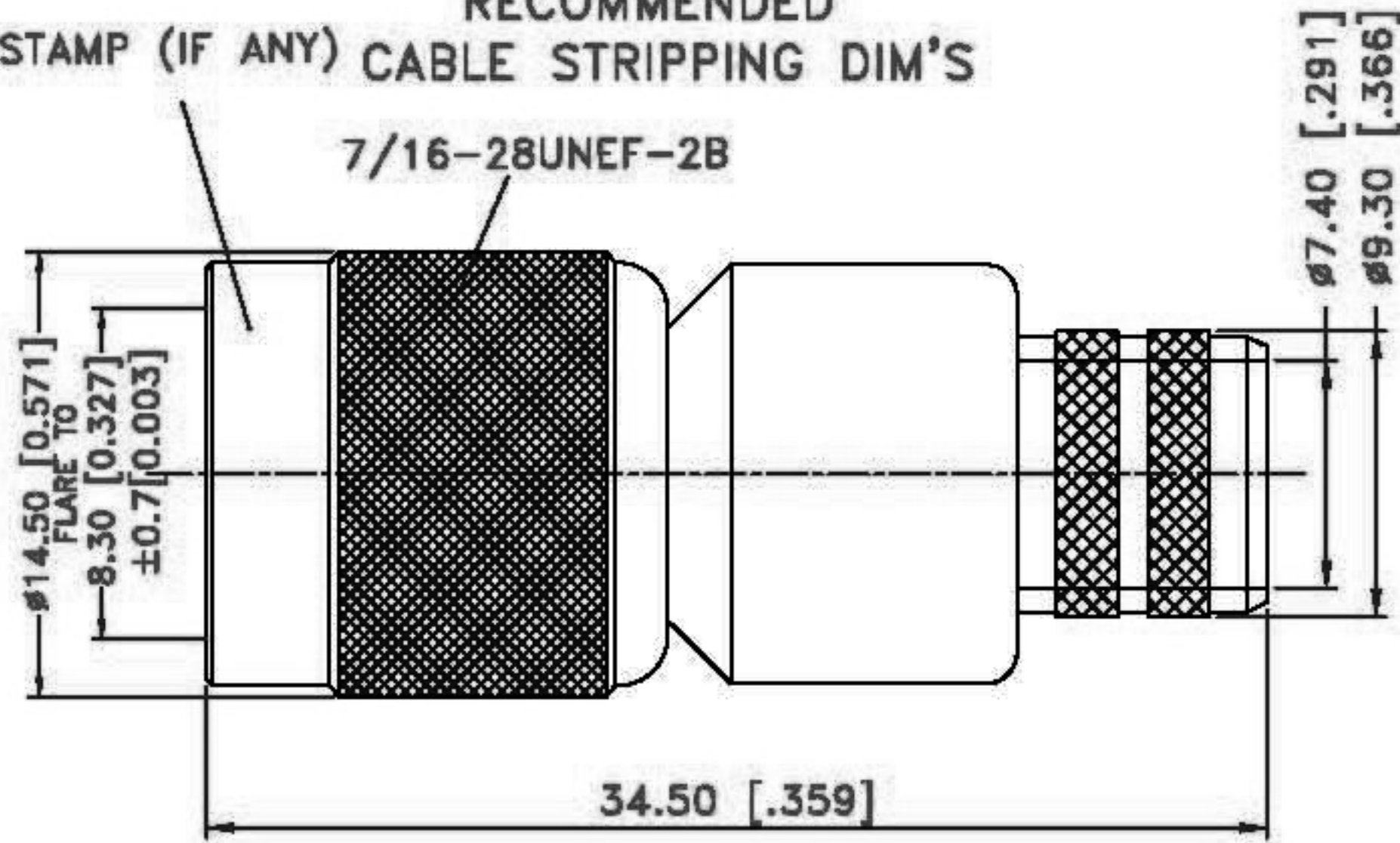

NOTE:

1. CRIMPED FERRULE HEX CRIMP SIZE .429"
2. CRIMPED CONTACT PIN HEX CRIMP SIZE .100"



ChoiceRight Electronic Inc

UNLESS OTHERWISE SPECIFIED DIMENSIONS ARE IN MILLIMETERS. DIMENSIONS IN [] ARE IN INCH AND FOR CUSTOMER REFERENCE ONLY.

UNLESS OTHERWISE SPECIFIED TOLERANCES FOR MILLIMETERS ARE:
 0.5 - 8mm ± 0.20mm
 8 - 30mm ± 0.40mm
 30 - 120mm ± 0.50mm

UNLESS OTHERWISE SPECIFIED TOLERANCES FOR INCHES ARE:
 .20 - .315 = ± 0.007"
 .315 - 1.180 = ± 0.015"
 1.180 - 4.724 = ± 0.020"

PART DESCRIPTION
TNC Straight Crimp Plug

CHECKED
J. Lin

PART NO
TNCMS00102B5000-1

DRAWER
Eddie

FILE NO. D:\

EDITION: A DATE 05/01/04 SCALE NA UNIT MM

4	FERRULE	COPPER	NICKEL	1
3	INSULATOR	BRASS	GOLD	1
2	CONTACT PIN	TFTLON	NATURAL	1
1	BODY	BRASS	NICKEL	1
	DESCRIPTION	MATERIAL	FINISH	QTY